

FILE NO!

ScotRail - D of S & TE		
SYSTEMS ENGINEERING		
Title		
LINE ROUTING CARD		
Size	Document Number	REV
B	90SES3	
Date:	February 28, 1991	Sheet 1 of 4

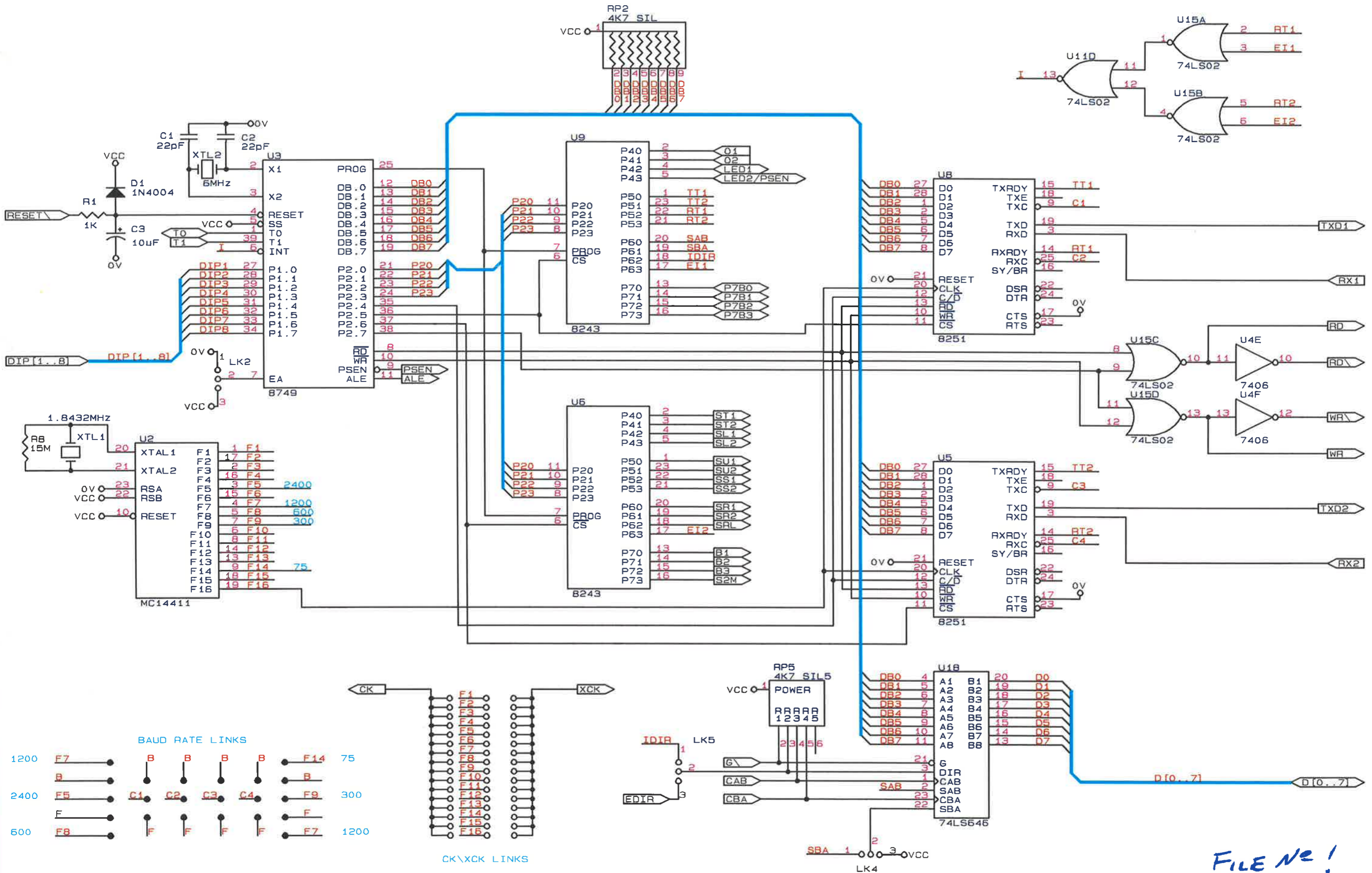

BAUD RATE LINKS

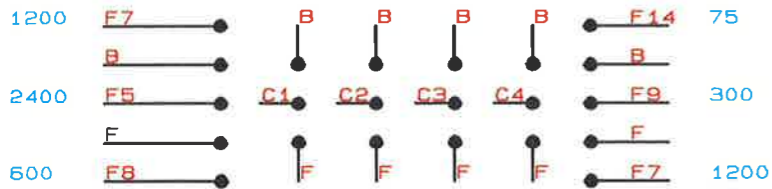

CK\XCK LINKS

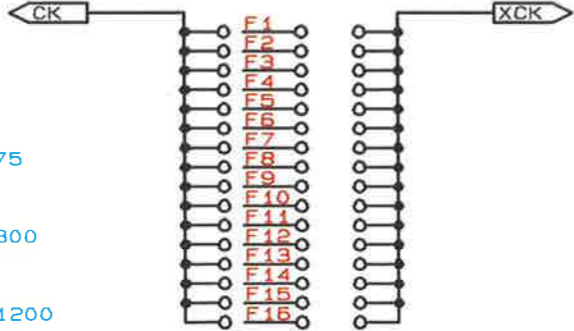

ALL LINKS & JUMPERS ON 0.1" PITCH

FILE No!

ScotRail - D of S & E	
SYSTEMS ENGINEERING	
Title	
LINE ROUTING CARD	
Size	Document Number
B	90SES3
Date:	February 28, 1991 Sheet 2 of 4

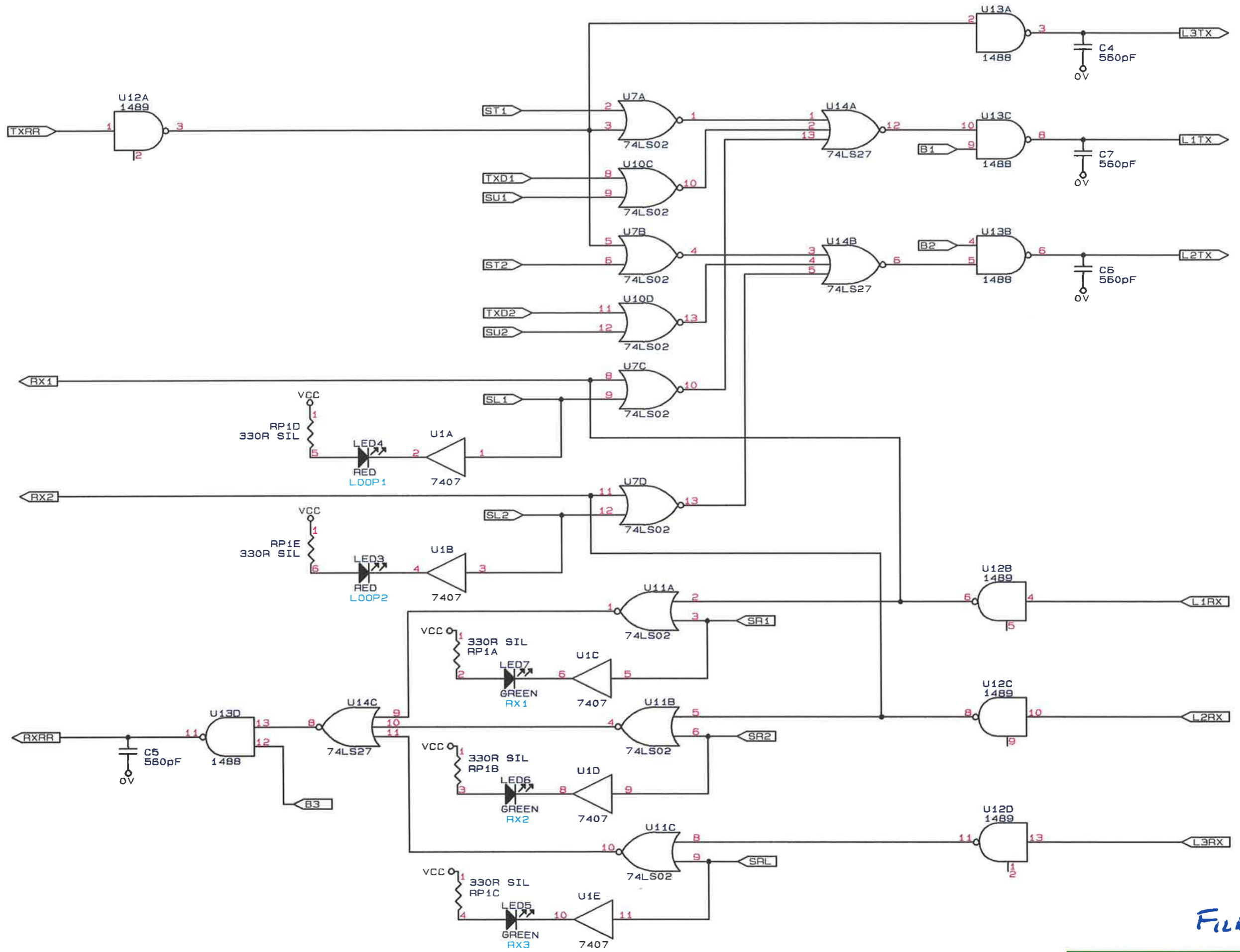

FILE NO!

ScotRail - D of S & TE		
SYSTEMS ENGINEERING		
Title		
LINE ROUTEING CARD		
Size	Document Number	REV
B	90SES3	
Date:	October 22, 1990	Sheet 3 of 4

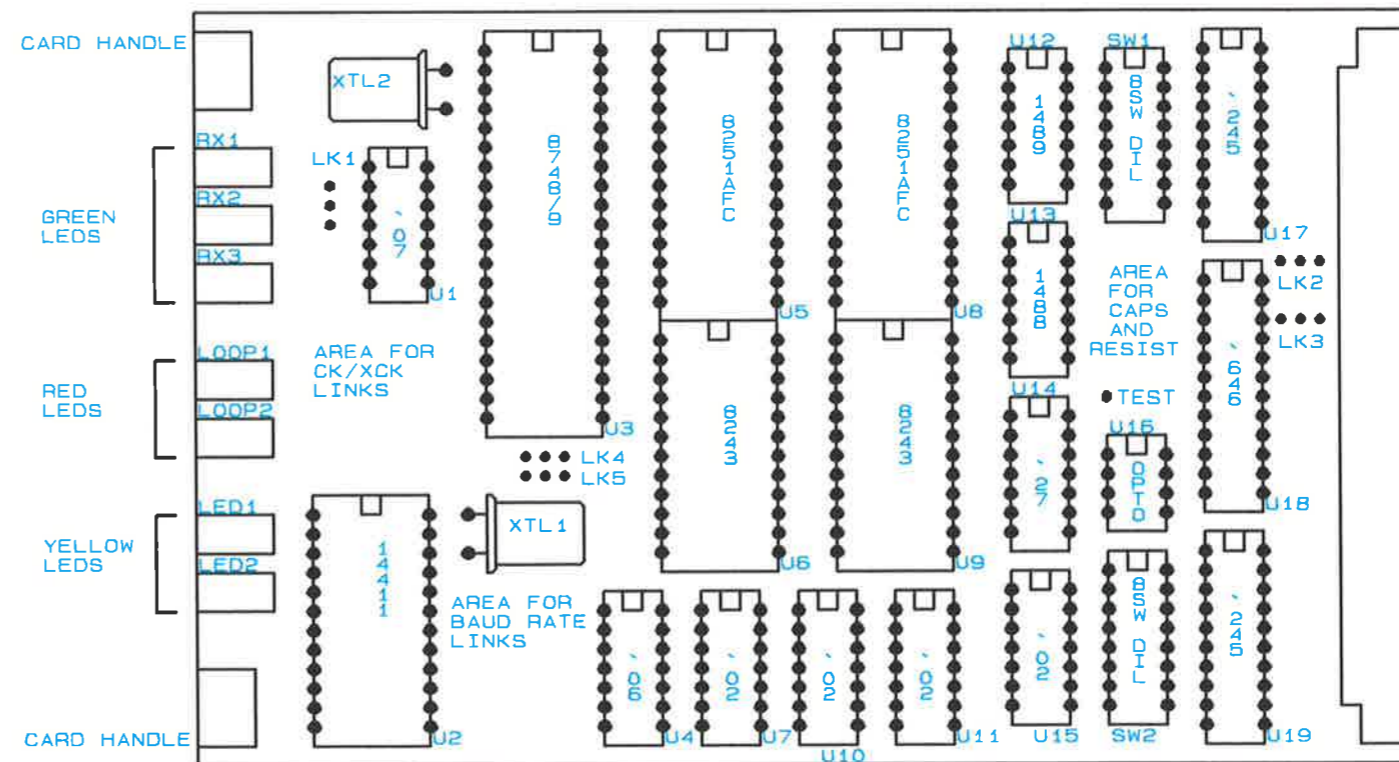

NOTES:

- 1) Card handles to be BICC-Vero Type No.21-18886 (Flexible Card Handle)
- 2) Links and Jumpers to be wire-wrap posts on a 0.1" matrix (eg 3M BMIC 0.100" Header Pin Strip available from STC)
- 3) LED's to be Quality Technologies Flat Top rectangular, Type MV57123 etc. (STC 009884E)
- 4) JP23 Test Point to be RS 434-138

FILE NO!

ScotRail - D of S & TE		
SYSTEMS ENGINEERING		
Title		
LINE ROUTING CARD		
Size	Document Number	REV
A	90SES3	
Date:	February 4, 1993	Sheet 4 of 4